

POWER YOUR FUTURE

Weichai Generator
LG1100WP

12M33D1320E200

Prime Power: 1100W/1375KVA

Standby Power: 1210W/1512KVA



GENERATING POWER SOLUTIONS

Increased availability for new operations

Reliable, robust and versatile generator.
Ready to deliver power for a next job.

Increased uptime during operations

Once installed on the end-user-site, the generator will be ready to run: "peace of mind" operation.

Reduced transport and installation costs

The compact and robust design with integrated transport features enables faster and safer transport and installation.

Reduced service & maintenance costs

Longer service intervals.
Quicker and more efficient service jobs.

Premium resale value

Designed and built to last.

SAFETY

- Operate safely in accordance with proper operation manual.
- To prevent trouble and accidents, perform daily and preventive maintenance checks without fail.

Weichai Baudouin Series

500KVA--42000KVA



FUAN LONGKAI POWER CO.,LTD.

Headquarters:

Add: Wei 5 Road, Tiehu Industrial Zone, Fuan, Fujian, China

Tel: +86-0593-6309773 Fax: +86-0593-6586988

E-mail: sales@longkaipower.com

Web: www.longkaipower.com

Technical Data

LG1100WP

Model	LG1100WP	
Rated prime power	kva	1375
Rated standard power	kva	1512
Rated voltage line to line	V	400/230
Rated current	A	1985
Maximun sound level	dB(@7m)	≤103

Engine-Weichai

Model	12M33D1320E200	
Aspiration	Turbocharging and intercooling	
Fuel system	Mechanical Pump+Electronic Speed Governor	
No. cylinders	V 12	
Displacement	Liquid	39.2
Bore*Stroke	mm	150*185
Compression ratio	15:01	
Rated speed	r/min	1500
Rated net power(with fan)	Kw	1200
Governor type	EFC Electrical	
Start Motor	V	24

Exhaust System

Exhaust gas flow	L/s	7315.4
Exhaust gas temp	°C	550
Max back pressure	kPa	7.5

Aspiration System

Max inlet pressure	kPa	≤3
Combustion volume	kPa	/
Air flow	L/s	7038

Fuel System

100% load(Prime power)	L/h	268.6
75% load(Prime power)	L/h	/
50% load(Prime power)	L/h	/
Fuel tank capacity	L	2500
	(External Fuel Tank)	

Lubrication System

Oil capacity	L	117
Oil consumption	g/kwh	0.3
Oil pressure	kPa	400-650
	(continuous operation)	

Cooling System

Coolant capacity	L	83
Thermostat operation range	°C	80-92
Max water temperature	°C	103

Alternator

Model	LONGKAI	LK734B
	STAMFORD	PI734B-S6L1D-H4
Phase	3	
Voltage	V	400/230
Wiring Type	3 Phase 4 wire, Y type	
Bearing	1	
Power factor	0.8	
Frequency	Hz	50
Prime power	KW	1120
Exciter Type	Brushless, self-excitation	
Voltage regulation	%	±0.5
Protection Grade	IP 23	
Insulation grade	H/H	
Altitude	m	≤1000

Controller-DEESEA

Model	DSE6120MK3
-------	------------

Protective functions:

- Low oil pressure
- High water temperature
- High/low voltage
- High Engine Temperature and Overspeed.
- Voltage regulator frequency regulator
- Emergency stop
- Start failure



Control Module Options



- Auto generator control module
- Control module with "Three Remote Control" functions
- ATS auto load transfer screen
- Synchronising control modules
- Power output cabinet



Standard Features

- Engine(Weichai Baudouin)
- Radiator 50°C max,fans are driven by bel
- 24V charge alternator
- Alternator: single bearing alternator IP23, insulation class H/H
- Standard auto control system
- One set of air filter, fuel filter, oil filter
- Main line circuit breaker/MCCB
- Base fuel tank
- Two 24V batteries, rac and cable
- Exhaust system(Ripple flex exhaust pipe, exhaust siphon, flange, muffler)
- User manual

Options

- Battery charge
 - Engine heater
 - Alternator heater
 - PMG
 - Water oil separator
 - Daily fuel tank
 - Remote control panel
 - Automatic transfer switch/ATS
 - Switch box
- Standard: ● Options:○

Warranty*

Weichai Engine

12 months from date of purchase and 1000 hours.

Generator

12 months from date of purchase or 1000 hours (whichever occurs first).

Unit Dimensions(Basic unit)

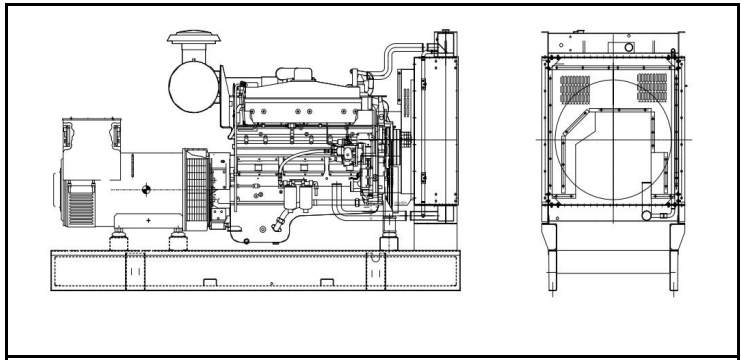

Open Type		
L*W*H	mm	5800*2090*2600
Weight	kg	10500

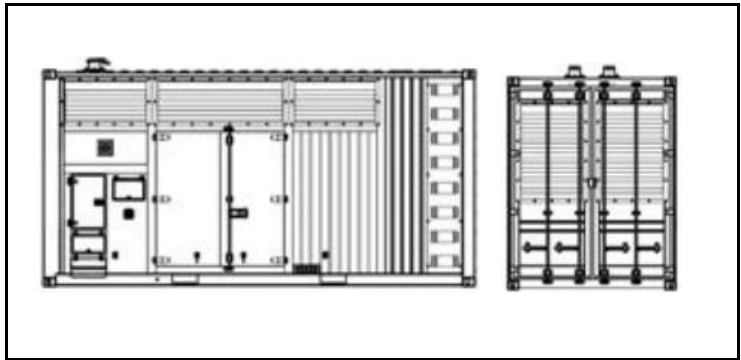

Silent Type(Standard 40'ft container)		
L*W*H	mm	12192*3438*2591
Weight	kg	18900



More information, pls refer to our web-site: www.longkaipower.com

Manufacturer reserves the right to make changes in model, technical specification, color, equipment and accessories without notice.